

Stabilizing Chilled Water Distribution

Author¹ Kecha Thirakomen
ASHRAE Thailand Chapter – BOG

¹ EEC Engineering Network Co., Ltd, 28th Flr. CP Tower2, Rachadapisek road, Bangkok 10400, Thailand, Tel: 0-2642-1200, Fax: 0-2642-1216-7, *E-mail: kecha_tr@eec.co.th



Abstract

Balancing of chilled water supply and return system has been a major backfire when operating a chilled water airconditioning system. Designer has applied “Reverse-Return” piping technique to equalize pressure at the begin branch line and the end branch line of the chilled water distribution. The technique is also used to equalize pressure on each terminal unit within each branch. After 2-way shut off control valve replaced conventional 3-way bypass control valve, engineer tend to design the chilled water branches with “Direct Return” piping in order to reduce cost and space requirement. “Variable Chilled Water Supply” with either “Primary-Secondary Pump” or “Bypass” has becoming a common design practice. 3 way bypass control valves might be used only at the end of line terminal unit to reduce pressure fluctuation and risk of water hammer.

Serious problems have been found based on imbalance of chilled water supply pressure, especially on large system and long piping distance. End of the line AHU lacked of flow and chilled water supply-return delta T did not comply with the design and normally return chilled water at lower temperature than design. Thus, the system does not reap the supply chilled water supply cooling energy effectively. The airconditioning system does not provide proper temperature and humidity that are too high and jeopardize the performance of airconditioning system.

We have pointed our finger at commissioning and balancing as the solution for the described problems. But less than 1 out of 100 projects that could perform such activity perfectly, due to many limitations, including immediate take over for soft opening, change of functions, new branches, new

Fig 1 : Modern terminal unit with air purifier



extensions, add on units, improper control of chilled water pump supply pressure, etc. Further than that, chilled water demand could vary from 10-120% of design flow. Therefore, system pressure has wide range of fluctuation. We can say that, most of the chilled water airconditioning system is “out of control”. Meanwhile, there is higher trend of delivering cooling by chilled water, with more district cooling projects. Deliver cooling by chilled water is in fact more efficient than cool air. Since water as the cooling media is more effective, require less energy to transport and less leakage in the system. Advanced airconditioning uses more “Terminal unit” as “Personal airconditioner”. New model might includes air purifier and have furniture look.

It is time for designers to upgrade chilled water distribution with more care and advanced techniques so that the system pressure will be more stabilized when system demand varies.

Keywords: Chilled water flow control

Introduction

This paper present that the designer should focus more on designing chilled water distribution so that supply chilled water pressure at each terminal unit (air handling and fan coil unit) is stabilized and maintained within differential pressure limit of the control valve. The designer should realize that chilled water pressure in the chilled water distribution system fluctuate due to operation of control valves. The fluctuation causes system chilled water pressure “hunting”, and control valve hunting as a consequence. Though the hunting in this case is a slow process, but it is enough to result in high chilled water fluctuated demand. In fact, this is the reason that chilled water demand in the system is over the chilled water supply from chiller plant. In other words, this is the cause of secondary chilled water flow that is more than primary chilled water flow in a primary/ secondary chilled water pump system. This is really a bad situation, and can be notified with following observation:

1. Return chilled water mix with supply chilled water in a primary/secondary pump system.
2. Common line between supply and return main chilled water pipe has been shut off by building engineer to avoid the mixing of chilled water supply/return in a primary/secondary pump system.
3. Chilled water supply temperature from chiller plant is higher than leaving chilled water temperature from chiller.
4. Secondary chilled water pumps are running more than primary chilled water pumps.
5. End of chilled water distribution line lack of flow.
6. Front of chilled water distribution line has too much flow.

Unstable chilled water distribution system consumes high pumping energy. High chilled water supply temperature, and lack of flow produces high room temperature and humidity. Be reminding that

Fig 2 : Selection and sizing of control is the key factor for the control of chilled water distribution system



a 1000 TR system requires approx. 50-60 kW chilled water pumping energy.

Therefore, balancing of chilled water distribution is the key factor for energy efficiency of a chilled water supply system. Stabilizing chilled water distribution system is also crucial in designing a district cooling system.

Causes

As described, unstable chilled water supply system is very undesirable. The problems become more critical when the system has been designed as “Variable

Chilled Water Flow”. In summary, the followings could be the causes of unstable chilled water distribution system:

1. Design with direct supply/return chilled water distribution.
2. Long chilled water distribution system with supply head of over 80 ft.
3. Improper control of primary/secondary pump.
4. Balancing of chilled water distribution branches.
5. Improper selection of control valve.

Though control valve, once properly selected and sized should be able to keep the system functioning, designers should not rely too much on control valves and believe that control valves will be able to offset system variables. In fact, that is not true, incorrect sizing of control valve always happen and this alone is already disastrous. Control valves have been sized too large by using pipe size as the size of control valve. That is at least one size larger than what would be required. There are many reasons why the control valves have wrong sizing, including the followings:

1. Some suppliers prefer to sell larger control valve.
2. Some design consultants prefer larger control valve.
3. Some project owners prefer larger control valve, because it is more expensive.
4. It is a government project.

We should always check the control valve authority (Pressure drop in the control valve fully open and design flow/Pressure drop across the circuit at no flow) that it is above 0.3 and preferable 0.5. Or balancing valve will be installed to supplement the flow control of the control valve.

Senior designers are familiar with “spring return” control valves, believing that they are “fail safe”. However, they might not be able to provide enough “shut off pressure” for larger system. Even with motorized control valve, maximum shut off pressure is normally only 120 ft. When designer design long direct return piping, they may specify too high chilled water pump head, in order to safe guard that chilled water pressure will be sufficient for end of the line air-handling unit. You may be surprised to learn that there is a project where chilled water supply pump head is almost 250 ft! In this case, it is almost impossible to have a balanced system.

How to

Today, designers are designing chilled water distribution system with variable chilled water flow, and new generation engineer may not understand why old generation engineer were designing chilled water distribution system with constant chilled water flow and 3-way bypass control valves. At that time, designers were relied on 2.4 gpm/TR chilled water demand requirement, and maintained this requirement for the whole system. When energy has been of concern, variable chilled water flow came in. Chilled water supply pump could be single station with bypass control valve or primary/secondary pump arrangement. 2-way shut off control valve have replaced 3-way bypass control valve. When 2-

Figure 3: Conventional chilled water distribution system with reverse return piping

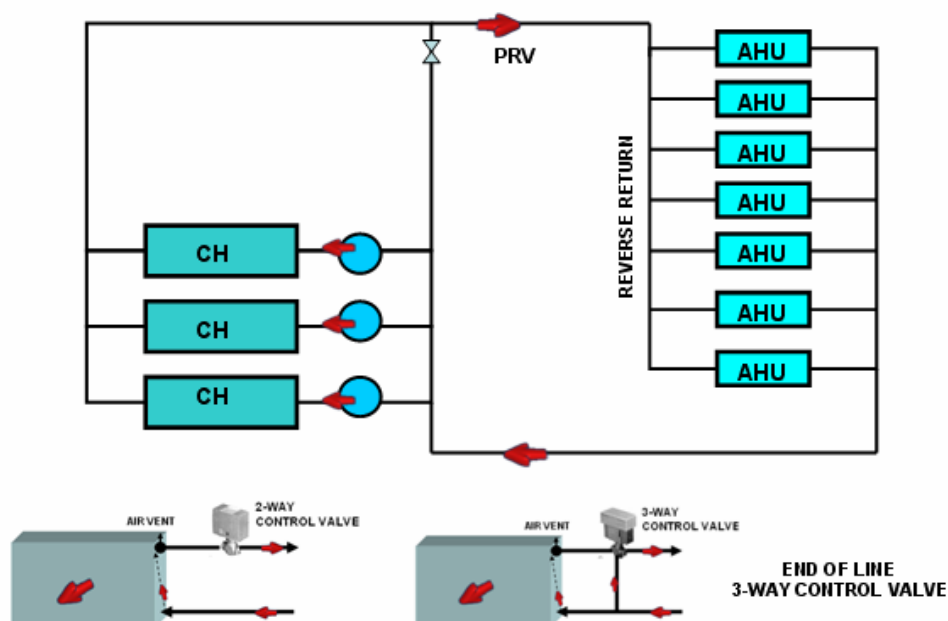

way shut off control valves could cause chilled water flow fluctuation or water hammer due to quick opening or closing, it is advisable to install 3-way bypass control valve at end of line fan coil unit as relief valve.

CIBSE Knowledge series: KS7 “Variable flow pipe work systems” is a good reference to start with. The book provides how to calculating pump energy savings, sizing control valves, self-balancing layouts, flow balancing, pump speed control, differential pressure control valves (DPCVs).

In my opinion, an ideal system is the system with self-balancing with reverse-return piping system or loop piping. Long radius elbow (which is long forgotten because it is more expensive and contractor always come with short radius elbow) should be used for the loop piping. Balancing valves should be installed at every branch circuits and air-handling units. It should be noted that balancing valve in normal operation will not impose unnecessary pressure drop to the system. Control valves should be properly selected with authority above 0.3. For larger system, it is preferred to install DPCV on each main branch, in order to control increased circuit chilled water pressure during part load within 50%. Shut off pressure rating of the control valve should be higher than chilled water distribution circuit pressure. In case that the chilled water supply pressure head is higher than 80 ft, it would be a good idea, to divide the chilled water distribution into different pressure head circuit. For example, high/ low pressure head circuit or high/ medium/ low pressure head circuit. Such arrangement will also provide more efficient chilled water supply pump energy consumption.

Designer could also specify AHU with higher pressure drop during 1/3 of the first distribution length, medium pressure drop for the middle length and lower pressure for the end of the length. Pressure drop could be in the range of 15-30 ft. The designer could also size the pipe with less friction loss for the end length. Another technique is pre-throttling balancing valves during 1/3 of the first distribution length and the middle length more than the end of the length. That will assist the process of

Figure 4: Primary/Secondary chilled water distribution system with reverse return piping

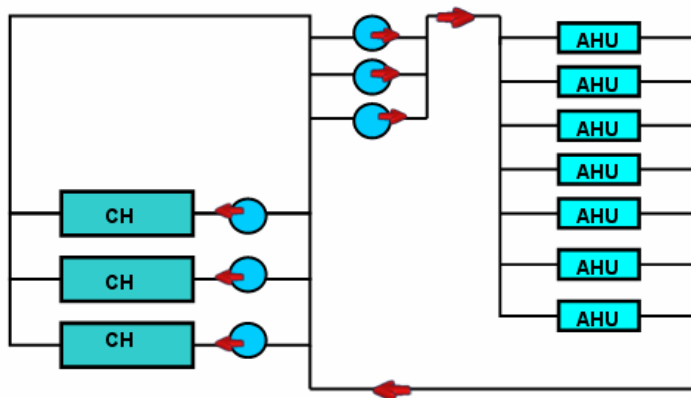
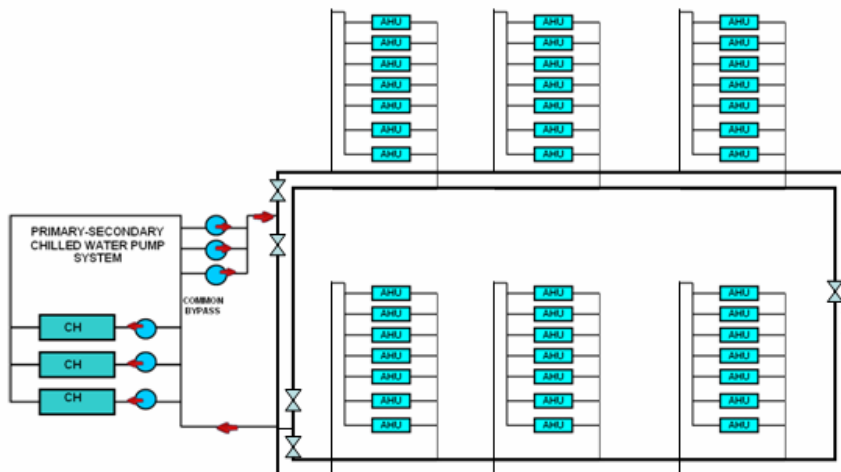

Figure 5: Primary/Secondary chilled water distribution system with reverse return and ring loop piping



during commissioning.

Balancing chilled water distribution system is a necessary procedure during system commissioning. Normally, it would take a few months to adjust balancing valves back and forth for at least 3 rounds.

CIBSE has also provided guideline for “Commissioning of variable flow pipe work systems”

There are also new soft wares that could assist designer on piping design. These

Fig 6 : Balancing valve and DPCV is the effective tool of system balancing

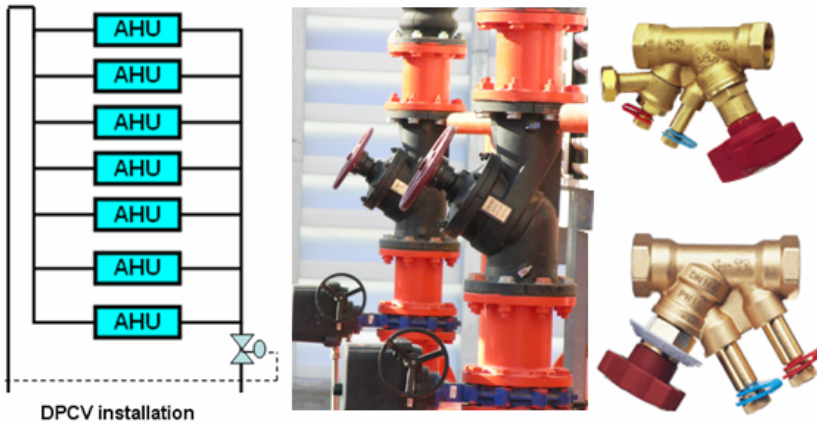

software could help designer to plan the system pressure at begin

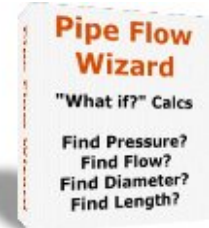

branch line and end branch line. Calculate the differential pressure at each branch so that it will be within limit.

Caution should be made on installation of expansion tank, so that there will be enough system head pressure on the highest AHU to facilitate cooling coil air purging at the air vent.

Goal

A stabilized chilled water distribution should have the following characteristics:

1. Chilled water demand of less than 70% of chilled water supply, or secondary chilled water flow of less than 70% of primary chilled water flow.
2. Chilled water supply temperature is the same as leaving chilled water temperature from chiller.
3. Chilled water return temperature is rather constant at all load condition.
4. Stable chilled water supply pressure at every chilled water branch line.
5. Chilled water flow is balanced at varied demand.

Chiller plant piping

It is recommended that each chiller should be connected to its companion pump, one by one. When pumps are connected with header, it is impossible to control desired flow to each chiller equally. One by one configuration will assure that each chiller will have the desired flow, no matter how many

Fig 7 : Chiller plant design with individual companion pump and short run to minimize system friction loss

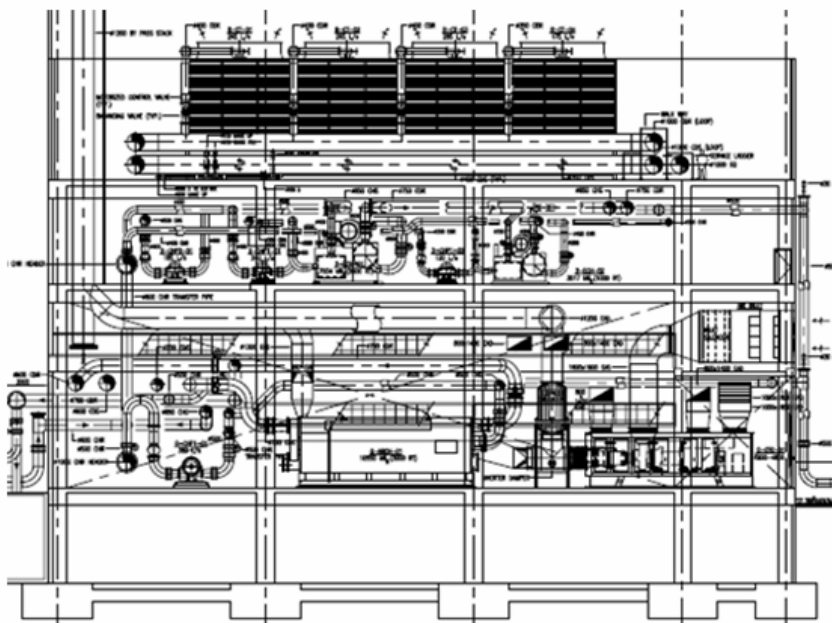

ENERGY CENTER

chillers are running. With the trend that chiller compressor will be equipped with variable speed drive and run at different load condition more efficiently, companion pump water flow can also be varied with the chiller. Thus, save significant pump energy.

There are options for variable chilled water distribution with single chilled water pump or with primary/secondary pump system. In my opinion, primary/secondary pump system is the

choice. Someone feel that primary/secondary pump system is too complicate and there are many case that secondary flow surplus primary flow. Again, stabilizing chilled water distribution is the key. A good design will have secondary pump control with differential pressure sensor at 2/3 distance of the load mapping. If there are DPCVs on every branches, CIBSE recommend to polling differential

pressure sensors located across the most remote DPCV controlled branches on each level. By polling the differential pressures across all of the most remote DPCV controlled branches, the lowest of the values obtained can be used to signal the pump to increase or decrease speed.

Chiller plant should be designed as a “Building heart”, where the chiller plant is part of the “Energy center”, including electrical substation. Chillers, pumps and cooling towers should be arranged in such a way that the piping is short and straight forward. Minimizing valves, fittings will minimize system friction losses and cost.

Common basin for cooling towers will avoid over flow and under level of any cooling tower.

Different chilled water supply temperature in a system

There could be a more sophisticated system where there are requirement of different chilled water supply temperatures in the same chilled water distribution system. For example, hospital project where 5 C chilled water supply temperature would be required for OR, while normal 7 C chilled water supply temperature is sufficient for most area. When 6-7 C chilled water supply temperature would be required for outdoor air unit, 7-8 C chilled water supply temperature would satisfy most area. Radiant cooling may require 13 C chilled water supply temperature. In such case, chilled water distribution could be split and designed as dedicated chilled water distribution system for each required chilled water supply temperature.

Conclusion

Stabilizing chilled water distribution system is the basic engineering knowledge for air-conditioning engineer. Content in this paper is nothing new, more like a reminder. But why there are problems on chilled water distribution balance everywhere. Designers, contractors in this field should pay more attention to all these basics. Proper sizing of control valves, self-balancing layouts, flow balancing, pump speed control are the important key factor of the chilled water distribution system. There are also better balancing valves available with reasonable investment. Differential pressure control valves (DPCVs) or even pressure regulating valves (PRV) could be worthwhile for large and long distance chilled water distribution system. **It could be concluded that a good chilled water airconditioning system should have a stabilized chilled water distribution system.**